



8-STACK MULTI-STATION

LEGO-Style Modular Training Station
More Freedom in Space
More Efficiency in Training

4-Stack Multi-Station SH-G7231



8-Stack Multi-Station SH-G7233A



Modern Minimal Design
Elevates Facility Image



Modular Configuration
Fits Any Training Space



Integrated Training Hub
Multi-User Training

MULTIPLE TRAINING STATIONS, FULL-BODY MUSCLE COVERAGE

Covers all major muscle groups and meets diverse training needs.

ADJUSTABLE PULLEY

Through free adjustment of pulley angles and heights, combined with various training attachments, it enables the execution of over a hundred training movements.

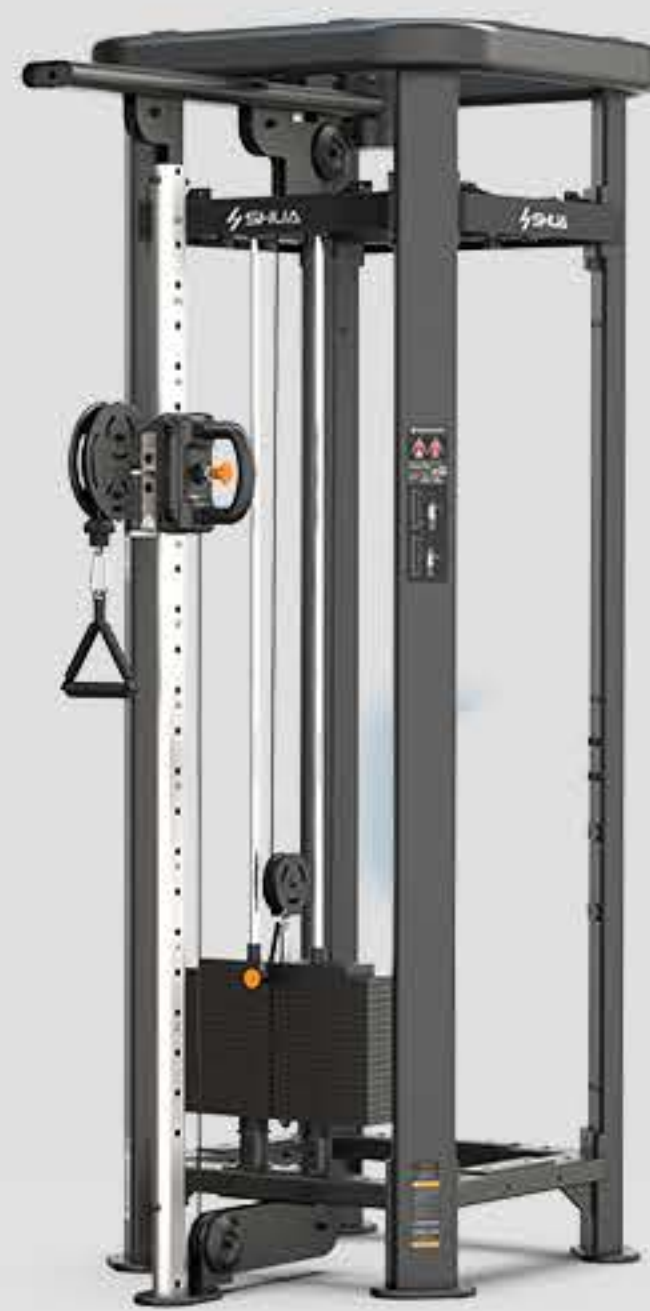

LAT PULLDOWN

Focuses on building a broad back, helping to shape an upright and powerful upper body.



DUAL PULLEY PULLDOWN

Improves imbalances in back muscle development and targets correction of strength disparities between the left and right sides.



LOW ROW

Comprehensively develops all back muscle groups, building exceptional back thickness and strength.



DUAL CABLE ROW

Easily achieves alternating or unilateral strengthening training, optimizing muscle detail and control.



Triceps Pushdown

Quickly increases arm circumference and sculpts ideal arm lines.



ASSIST DIP-CHIN

Multiple grip positions for training, with adjustable weight assistance to rapidly enhance upper body strength.



CROSSOVER CONNECTOR BAR

Classic bodyweight training position strengthens upper body and back functionality, building practical strength.

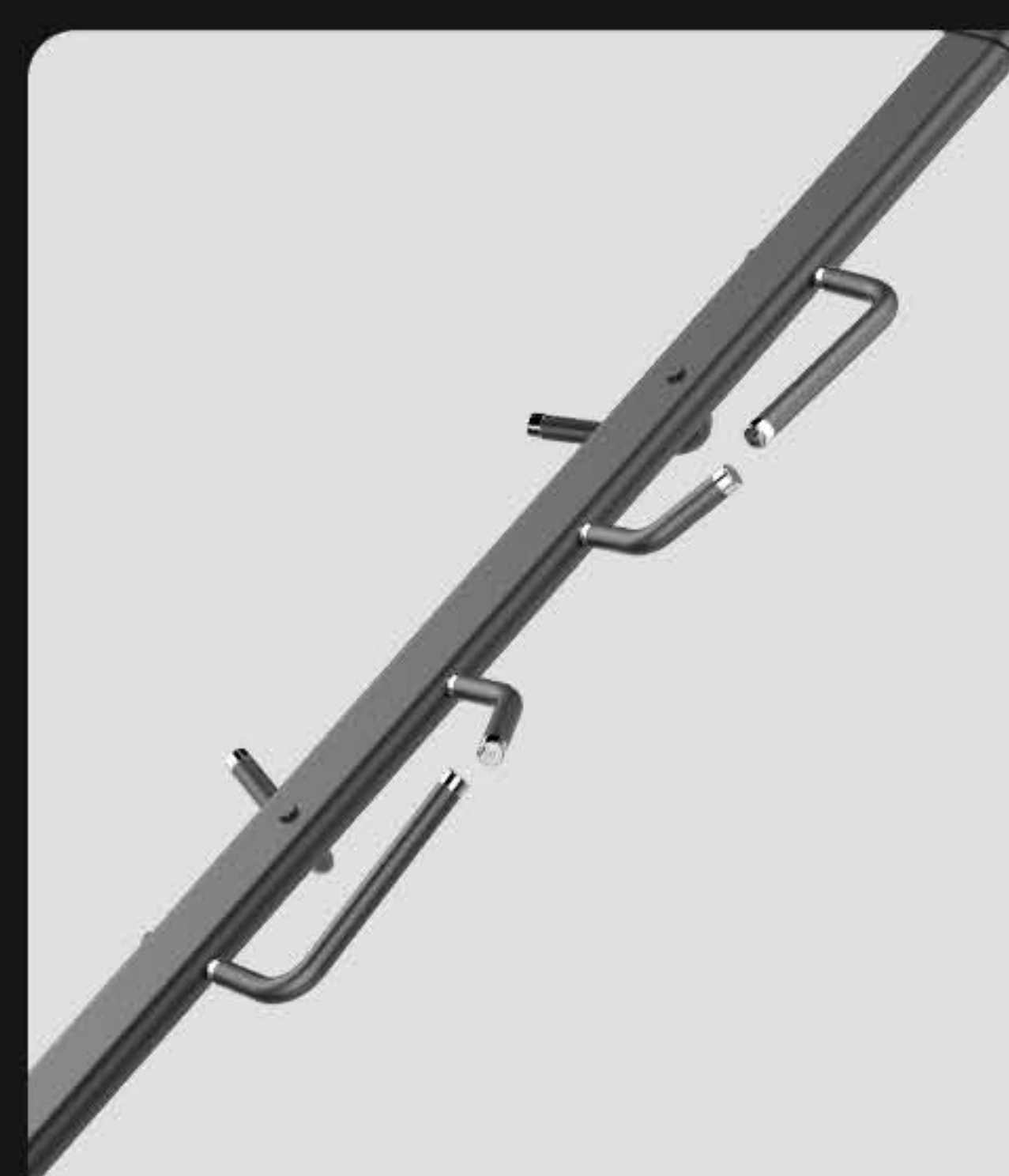

MAXIMIZE SPACE UNLOCK POTENTIAL

Compared to traditional single-station equipment, space efficiency increases by **50%**, enabling multifunctional training in limited areas.



MODULAR & FLEXIBLE LAYOUT

Modular design offers multiple configurations. Station placement adapts to different spaces, creating a personalized training environment.



4-Stack Multi-Station SH-G7231



5-Stack Multi-Station SH-G7232



8-Stack Multi-Station SH-G7233A



8-Stack Multi-Station SH-G7233B



water-drop holes

Secure High-Position Locking

Teardrop-shaped pin holes offer easier alignment and safer high-position locking.

One-Hand Adjustment

Single-hand adjustment with built-in pulleys for smoother vertical movement and effortless operation.

Smart Storage

Dedicated shelves and hooks keep personal items and accessories within easy reach.

High-Efficiency Integration Train Together

Eight functional stations integrated into one system, supporting up to nine users training simultaneously. Significantly reduces waiting time and improves training efficiency, ideal for team and circuit training.

4-Stack Multi-Station SH-G7231

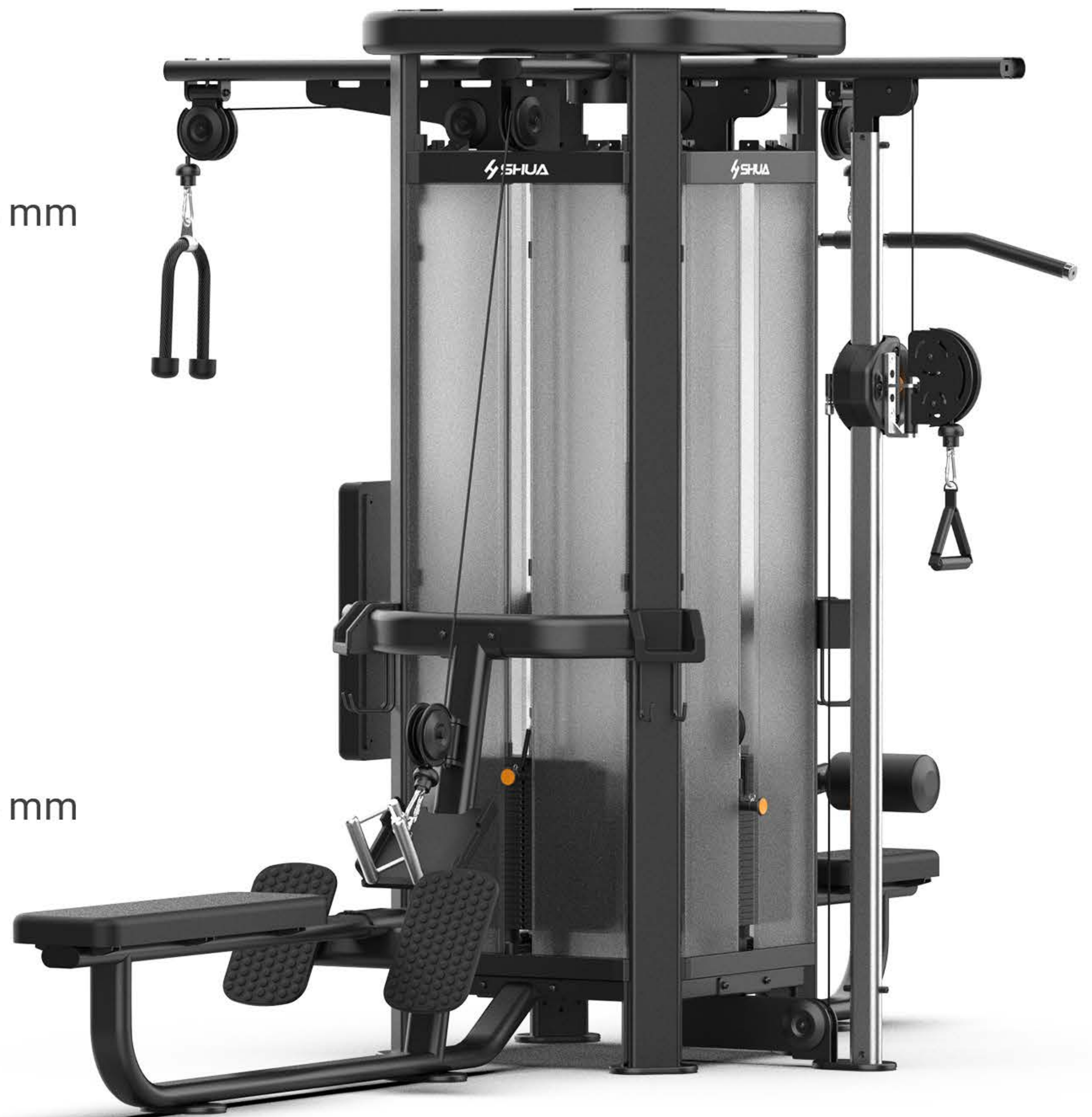
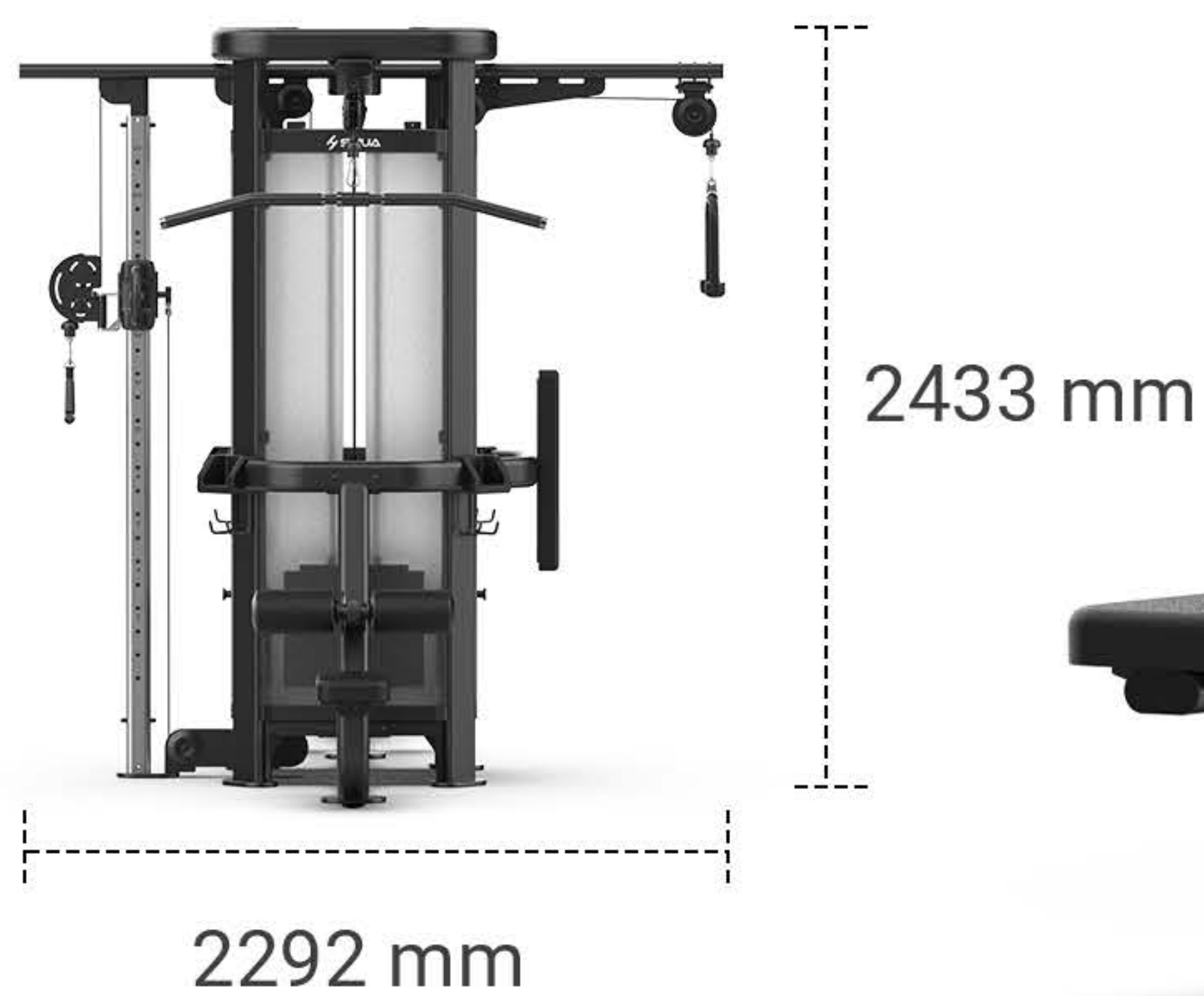
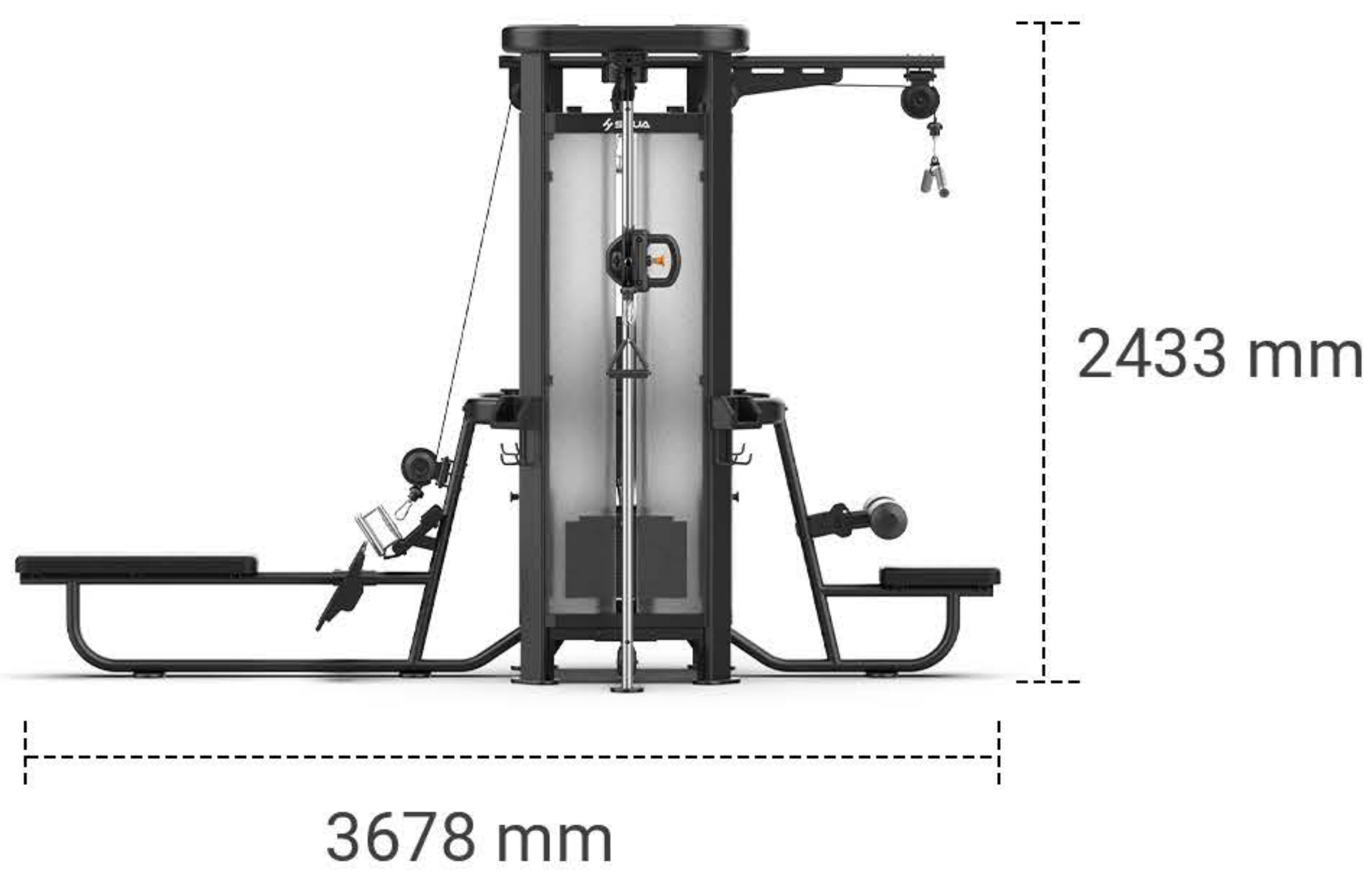

PRODUCT SPECIFICATIONS

Dimension	3678 × 2292 × 2433 mm / 145 × 90 × 96 in
Max User Weight	150kg / 331 lbs
Max Training Weight	130 kg / 287 lbs
Muscles	Multi-muscle Group Training
N.W.	464 kg / 1023 lbs
G.W.	549 kg / 1210 lbs
Loading Capacity	20GP: 8 units / 40HQ: 20 units

8-Stack Multi-Station SH-G7233A

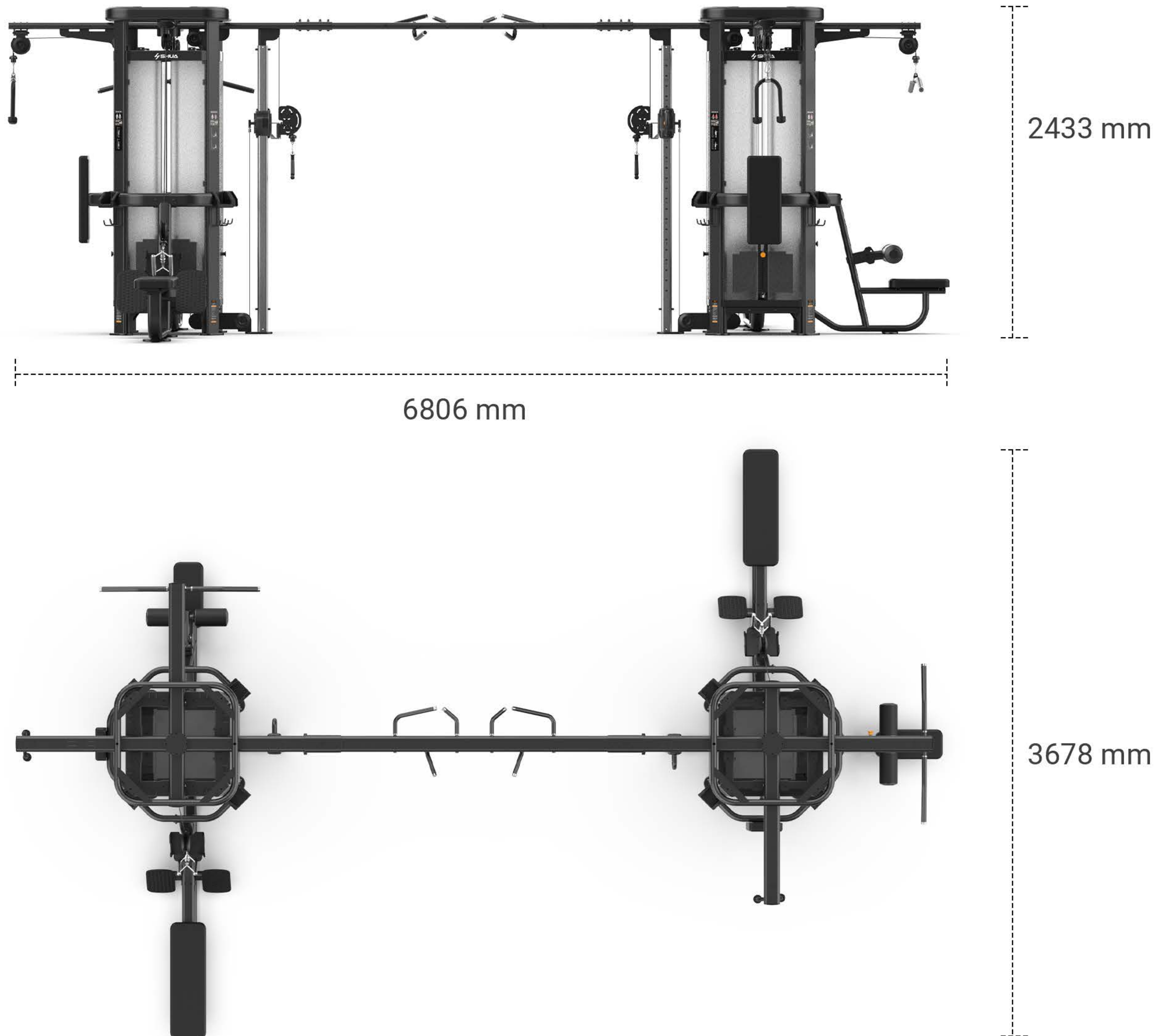

PRODUCT SPECIFICATIONS

Dimension	6806 × 3678 × 2433 mm / 268 × 145 × 96 in
Max User Weight	150kg / 331 lbs
Max Training Weight	130 kg / 287 lbs
Muscles	Multi-muscle Group Training
N.W.	962 kg / 2121 lbs
G.W.	1104 kg / 2434 lbs
Loading Capacity	20GP: 4 units / 40HQ: 10 units