



SH-G6371



Modular Safety Assistance for Confident Training

A half-arm safety catch offers support during failed presses, while the optional safety bar with 10 height settings adds enhanced protection against accidental drops.

Ergonomic Multi-Height Barbell Racking System

Three racking heights (high/mid/low) with dual hooks accommodate different users and lifting styles, ensuring easier lift-off and smoother setup.



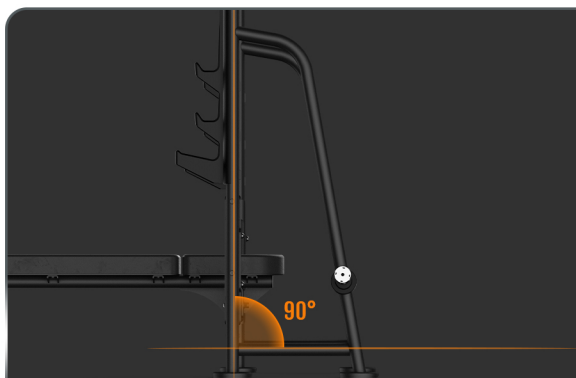

Vertical Load-Bearing Structure for Greater Stability

The vertical upright column with extended rear support replaces the traditional inclined design, improving load distribution and anti-tipping performance for safer heavy lifting and re-racking.

Targeted Free-Weight Bench Press Training Platform

Designed for free-weight pressing, the SH-G6371 primarily activates the pectoralis major, anterior deltoids, and triceps. Built for commercial strength areas, it delivers reliable performance for high-intensity, long-term use.

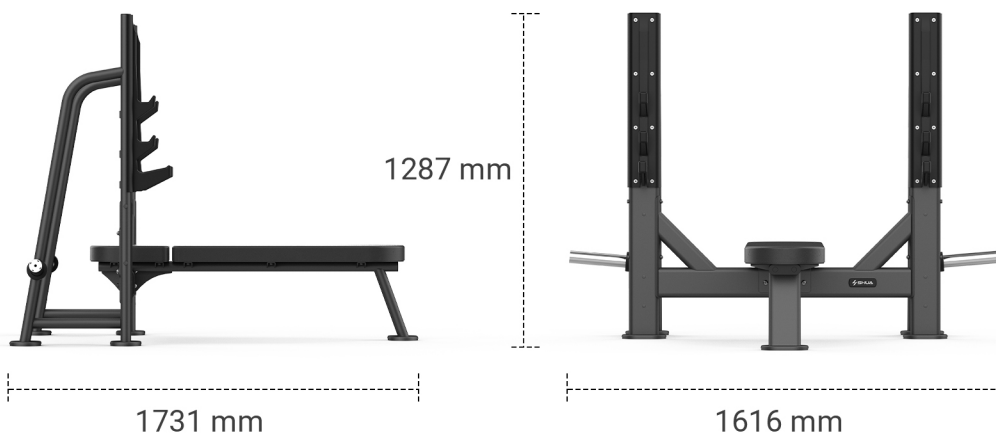

PRODUCT SPECIFICATIONS

Dimension	1731 × 1616 × 1287 mm / 68 × 64 × 51 in
Max User Weight	200 kg / 441 lbs
Muscles	Pectorals, Triceps, Deltoids
N.W.	65 kg / 143 lbs
G.W.	70 kg / 154 lbs
Loading Capacit	20GP: 40 units / 40HQ: 92 units